

ROAD RAGE

FX Type: Charge Pump / Voltage Inverter

© 2012 [madbeanpedals](#)

1" W x 1.2" H

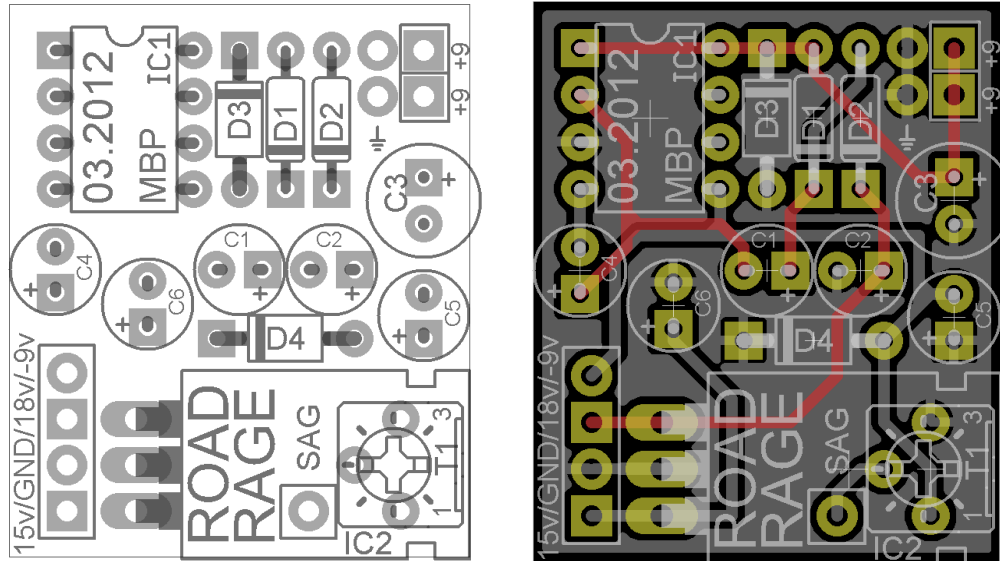

Revisions for the 03.2012 version – Fixed labels for 15v and 18v pads on the silkscreen layer. Added T1 (Sag) control for the -9v supply.

Documentation for previous version (11.2011) can be downloaded [here](#).

Schematic

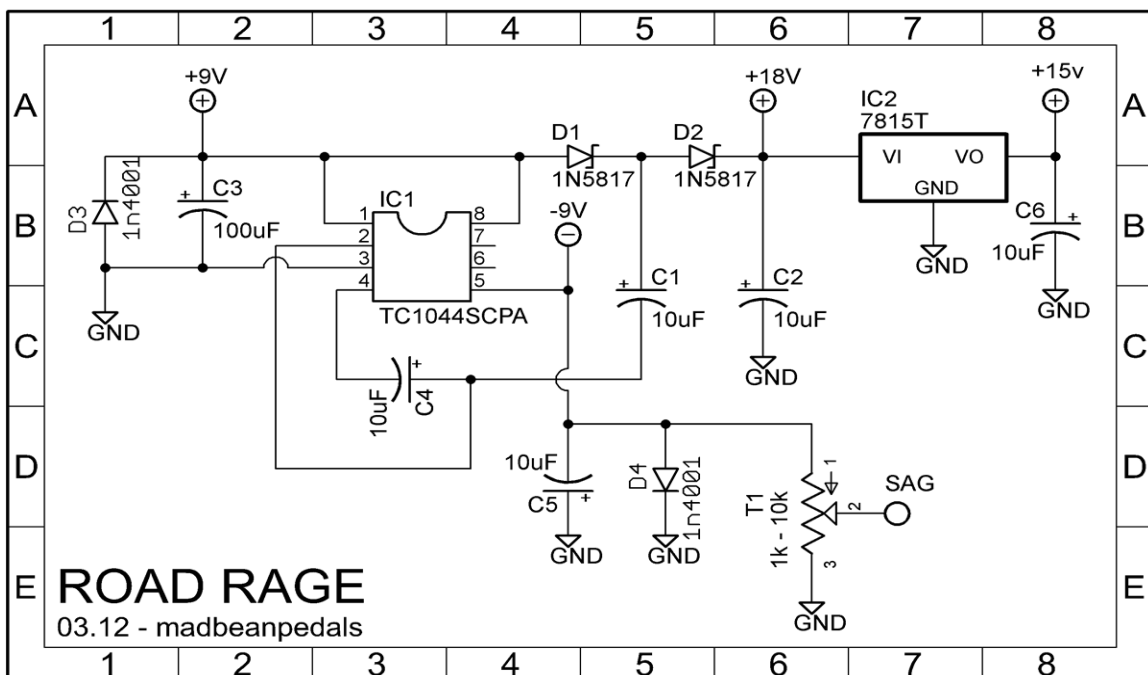

Bill of Materials

C1	10uF
C2	10uF
C3	100uF
C4	10uF
C5	10uF
C6	10uF
D1	1N5817
D2	1N5817
D3	1n4001
D4	1n4001
IC1	TC1044SCPA
IC2	7815T
T1	1k - 10k

Overview

The **Road Rage** is a utility PCB with four possible applications. At its core, the **Road Rage** utilizes a common charge pump to act as a voltage doubler. This allows one to supply the **Road Rage** with 9 – 12vDC and get approximately 18 – 24vDC out. The **Road Rage** also allows you to create a regulated voltage for instances when this is a requirement or a benefit in your circuit. Finally, the **Road Rage** acts as a voltage inverter and will output the negative side of the supply voltage.

Usage Examples

Voltage Doubler – For instances when a higher voltage than the supply is either needed or creates some benefit to a given circuit, for example, and overdrive that you want to run at 18vDC. In some situations, a circuit may require 18v to operate properly but the supply is limited to 9v from the source (wall wart or battery). The **Road Rage** will provide the added voltage needed (within the limitations of current supply).

Voltage Regulator – Some circuits require or operate most efficiently with a regulated supply. The **Road Rage** allows you to create either a 12vDC or 15vDC supply voltage from a 9vDC supply (note: higher supply voltages will NOT change the regulated output).

Voltage Inverter – The **Road Rage** also lets you take advantage of its inverter to supply positive ground effects, such as the Fuzz Face, with a standard negative ground 9vDC supply.

Sag control – This is an extension of the Voltage Inverter operation. It allows one to place either a variable resistor or voltage divider in series with the -9v supply for the purpose to simulating the “dying battery” effect with PNP germanium-based fuzz effects. The BOM lists 1-10k for the control, but a 5k pot/trimmer is very typical.

Limitations

While the **Road Rage** offers the convenience of extra voltage with relatively few parts the downside is its current supply power and voltage tolerance. The TC1044SCPA, MAX1044CPA and ICL7660SCPA can comfortably supply around 20mA which is fine for most overdrive type circuits but it isn't going to cut it in some current hungry circuits, such as a Univibe. These charge pumps also exact a certain cost in their output voltage due to the voltage drop across the charge pump diodes (**D1**, **D2**). A 9vDC supply will actually yield closer to 17 – 17.5vDC depending on what type of diode (i.e. what size forward voltage drop) is used. For this reason, the 1N5817 is suggested, although other diodes will work such as the 1N4001 and 1N914. The charge pumps are also limited by their own supply

tolerances. The maximum supply voltage when using the TC1044SCPA or ICL7660SCPA should be limited to 12vDC. For the MAX1044CPA it should be no more than 10vDC. You can use a 10 - 12v Zener diode as an alternative for **D3** to add extra protection for the charge pump, if you like.

Alternatives

You can use an LT1054 in place of the charge pumps listed above for approximately 2 – 3x the output current . The LT1054 is suggested for those circuits that have a high current draw, like the Univibe. The LT1054 is also rated for about 14vDC supply voltage.

Notes

Note that the **Road Rage** has pins 1&8 tied together on the PCB. This is because charge pumps utilize an internal oscillator as part of its function. This oscillator can dip into the hearing range in audio applications, resulting in a high pitched whine. Connecting pins 1&8 together acts as a multiplier for the oscillator and takes that frequency above the human hearing range, thus eliminating potential whine in audio applications.

This feature is used for the TC1044SCPA, MAX1044CPA and iCL7660SCPA. It is NOT used for the LT1054. This means that if you plan on using the LT1054, you either need to clip off pin1 on the IC, or use an 8-pin socket and clip off pin1 on the socket (suggested). Note that while the LT1054 does not use the frequency multiplier trick, it rarely yields detectable noise and is a perfectly fine (although more expensive) alternative.

For the ICL and TC varieties, make sure you get the “SCPA” version and not the “CPA” version. The MAX1044CPA should be fine. The “S” designation on the other two indicates a higher range boost function which is already present in the MAX version. Note that for the regulator IC, you can use either the T092 or T0220 type packaging.

Links

[TC1044SCPA @ Mouser](#), [LT1054 @ Mouser](#)

Before You Start

Make sure you have the proper charge pump, regulator (if needed) and sufficiently rated electrolytic capacitors. You should use 25v rated caps in most cases, although if you are only using the voltage inverter, 16v tolerance is fine.

Decide what application you are using and only load the parts needed for that function. You do not need to load the **Road Rage** with every component for all applications. Refer to the diagram below as a reference on which parts to use in which case.

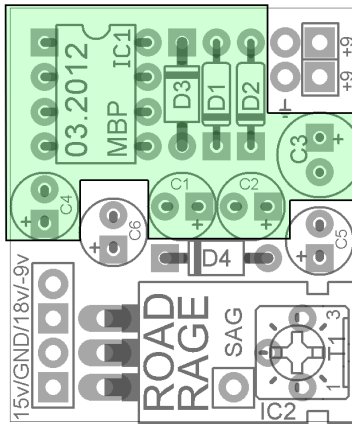

18v operation

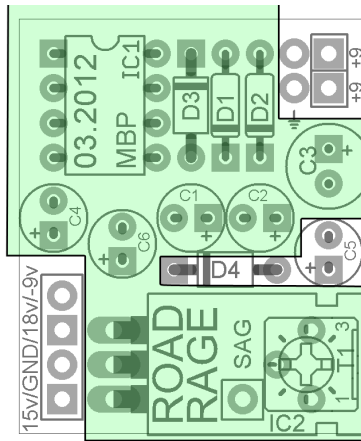

12-15v regulated operation

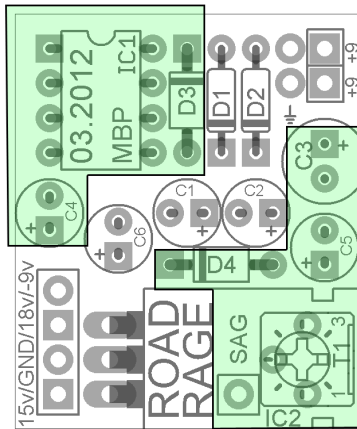

-9v operation

Overview

Using the SAG control for the “dying battery” effect:

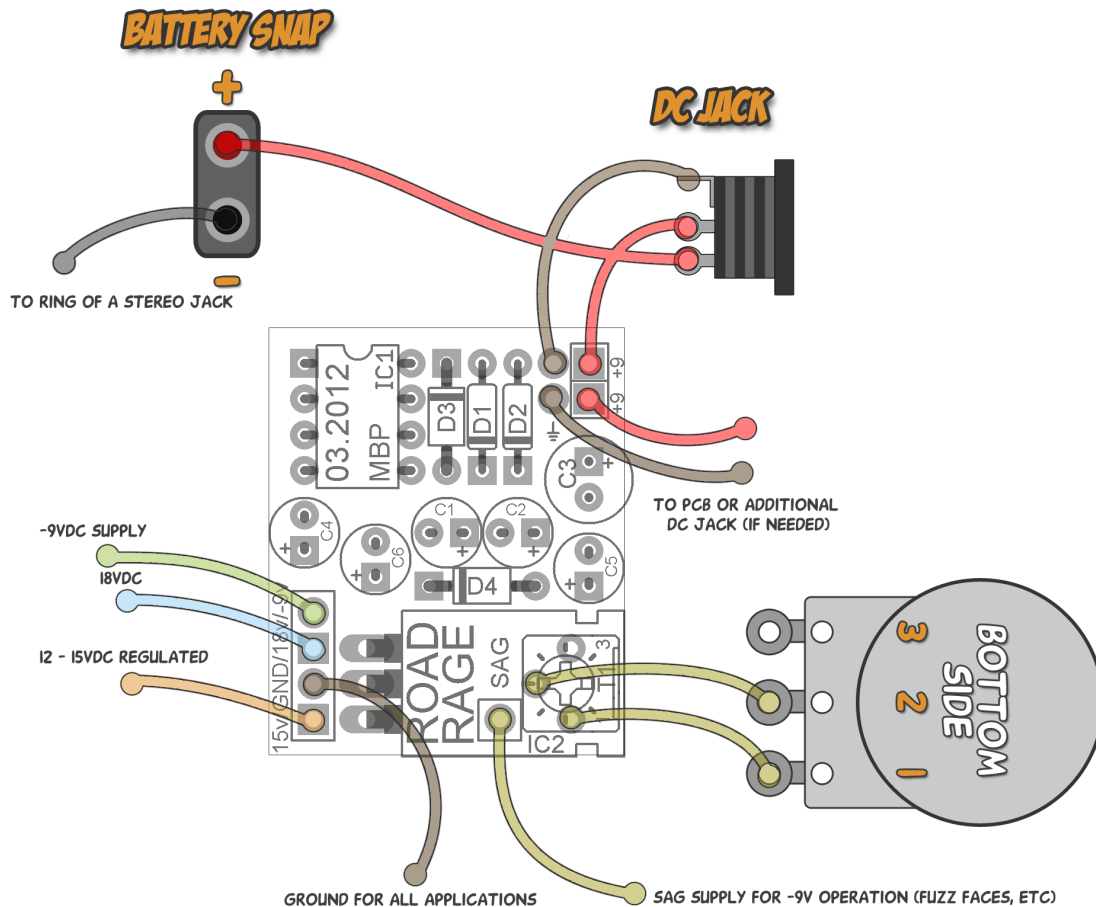

Method 1 (variable): Wire an external 5kΩ potentiometer to T1 as shown above and connect the SAG pad to the -9v pad on your PNP germanium fuzz. As the pot is turned clockwise, the -9v supply will decrease.

Method 2 (fixed): Use a trimpot soldered to the PCB instead of a wired potentiometer. Connect the SAG pad to the -9v pad on your PNP germanium fuzz. This allows you to set T1 to a fixed position for a permanent sag effect that cannot be altered.

NOTE: When using the SAG control, do not connect the -9vDC Supply wire (green wire above)! Use the SAG pad instead to connect to you fuzz effect.

Etching Layout

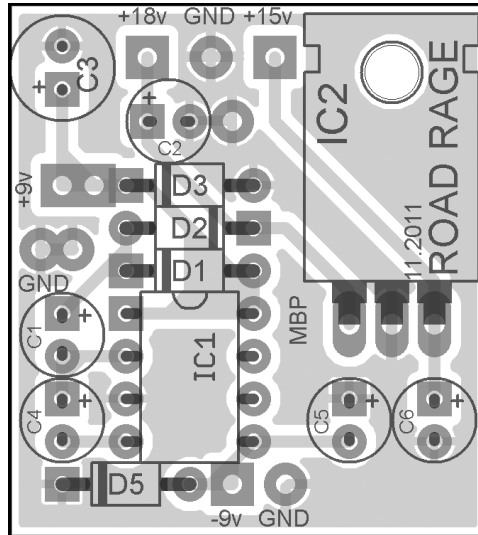

This layout does not include the “Sag” control

1.12”W x 1.25”H (w/ borders)

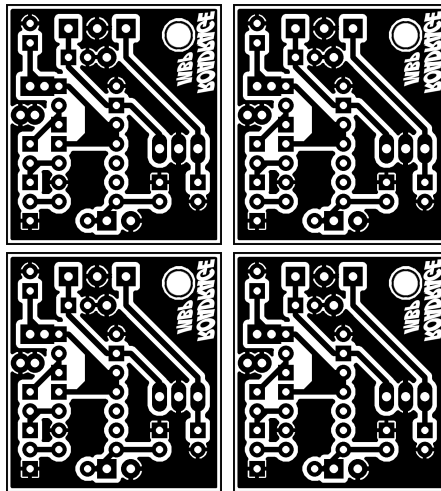

Licensing

You are free to utilize either a purchased **Road Rage** PCB from madbeanpedals or a self made (etched) version in commercial pedal products without prior permission or licensing. You may not, however, use the artwork to sell your own version of the PCB design or as part of a “kit” or similar commercial product.

www.madbeanpedals.com
BUILD.SHARE.LEARN